

版本 REVISIONS		
REV.版本	DESCRIPTION 说明	DATE 日期

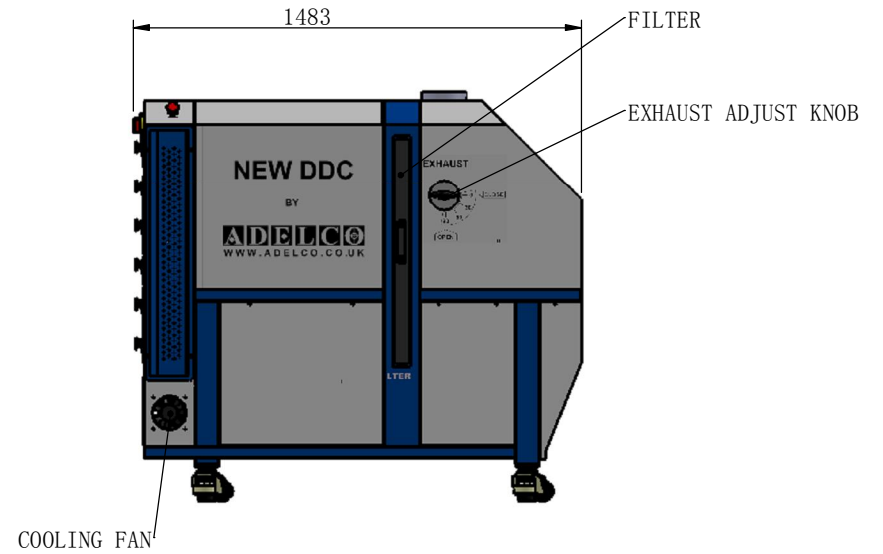
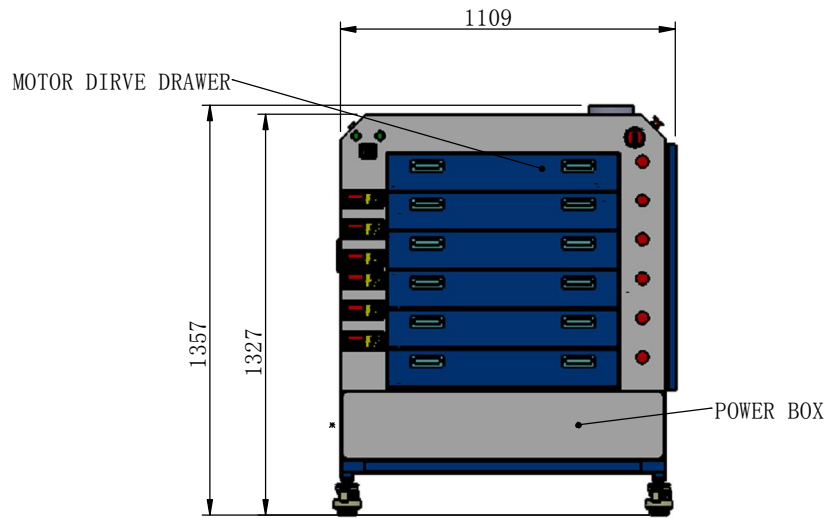
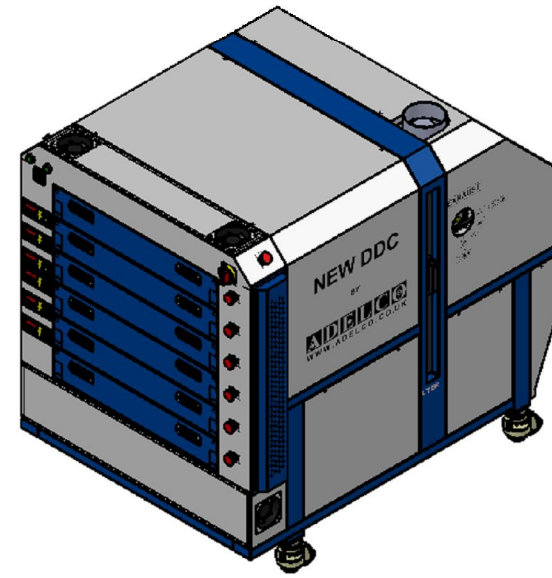
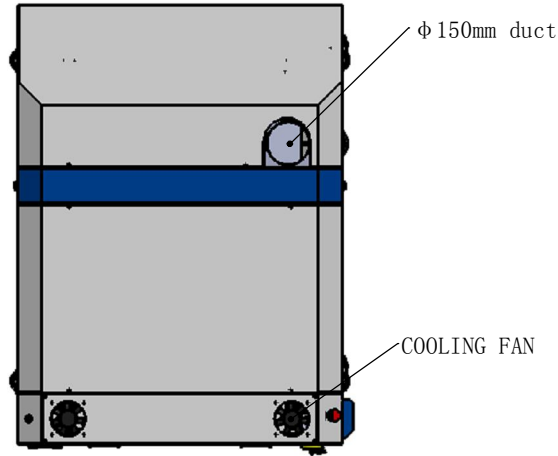

Material/材料:		Item name/零件名称:	
MACHINING NOTES/备注: TOLERANCES UNLESS OTHERWISE SPECIFIED/未注公差: LINEAR/线性尺寸: ± 0.1mm HOLES & INT. THREAD/孔及螺纹位置公差: $\text{H} \phi 0.1$ BREAK ALL SHARP EDGES/所有边去毛刺 0.1-0.4 RAD. OR 45° CHAMFER		Quantity 数量:	Scale/比例
第三视角 Third angle 		Drawn 制图:	1:25
所有尺寸是毫米 All dimensions are in mm		Checked 审核:	Weight/重量
		Date 日期:	Version/版本
		Finish/表面处理:	爱迪高 (昆山) 机电设备有限公司 ADELCO Highview, Hants, England GU350ax WWW.ADELCO.CO.UK
		Document-No. /图纸号码: DDC6-LAYOUT	
		A4	